

**REF. 3.038**

**CPMR27-V36-NOGAL Espejo**

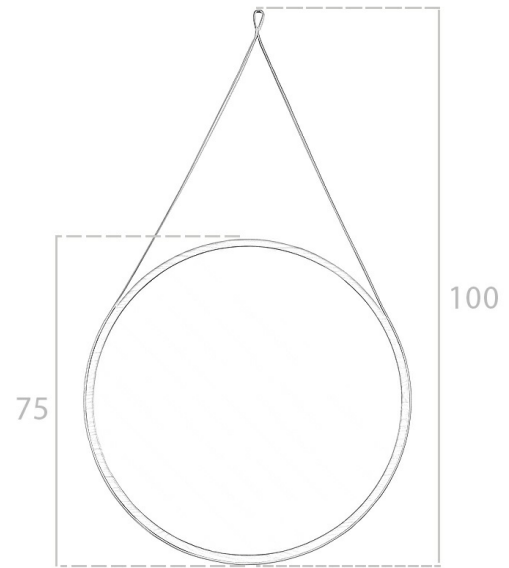

**MEDIDAS**

Medidas: Ø75 x 3 cm.

Peso: 6 Kg.

Forma: Redonda

**EMBALAJE**

85 x 84 x 37 cm. / 8 Kg.

**VOLUMEN**

0,09 m<sup>3</sup>

**PRODUCTO**

Chapa Nogal

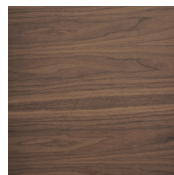

**PATAS**